

Single Acting Piston Seal Metric
CPU Imperial

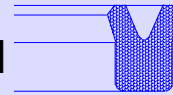
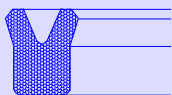

Design

The Claron style CPU is a symmetrical profiled lip seal manufactured in a high performance grade of Polyurethane and is suitable for both piston and rod sealing. The sealing lips are machine trimmed to ensure dimensional consistency and good low pressure sealing. Polyurethane exhibits outstanding abrasion and extrusion resistance.

Operating Conditions

Maximum Pressure		
Max Speed	Temp. Range	Temp. Range
m/s	-40°C to 80°C	-40°C to 110°C
0.50	280 Bar	250 Bar
0.15	400 Bar	350 Bar

These range parameters are Maximum simultaneous conditions.

Optimum service conditions are affected by temperature, speed, pressure, surface finish and extrusion gaps. Refer to Appendix 1 for further information.

Pressure Bar

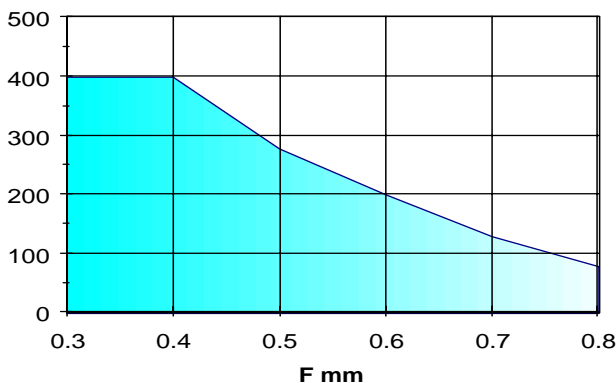

Continuous operating temperature for various Fluids

AU Polyurethane		
DIN	Hydraulic Fluid Description	°C
H	Mineral oil without additives	100
H-L	Mineral Fluid with anti corrosion and anti ageing additives	100
H-LP	Mineral oil as HL plus additives reducing wear, raising load	100
H-LPD	Mineral oil as H-LP but with detergents and dispersants	100
H-V	Mineral oil as H-LP plus improved viscosity temp.	100
HFA E	Emulsions of mineral oil in water. Water content 80-95%	40
HFA S	Synthetic oil in water. Water content 80-95%	40
HFB	Emulsions of water in mineral oil. Water content 40%	40
HFC	Aqueous polymer solutions. Water content 35%	ns
HFD R	Phosphoric acid ester based	ns
HFD S	Chlorinated hydrocarbon based	ns
HFD T	Mixtures of HFD R and HFD S	ns
HEPG	Polyglycol based	ns
HETG	Vegetable Oil based	60
HEES	Fully synthetic ester based	60

Maximum Diametral Clearance F

Note: Clearance gap F is the maximum permissible. i.e. gap completely on one side, in the temperature range of -30°C to 80°C. The use of a suitably selected Claron bearing ring will effectively reduce the clearance gap F max. to a value closer to F/2 thus increasing the pressure capability of the seal.

Housing

For surface finish and recommended lead in chamfers refer to the illustration below. For housing dimensions and machining tolerances refer to the catalogue page of selected seal. Refer to Appendix 4 for value of tolerance symbols. Refer to section C for rod application.

Fitting

For the seal to function correctly, it is important that care be taken in fitting the seal within its housing. For a detailed checklist, refer to Appendix 3.

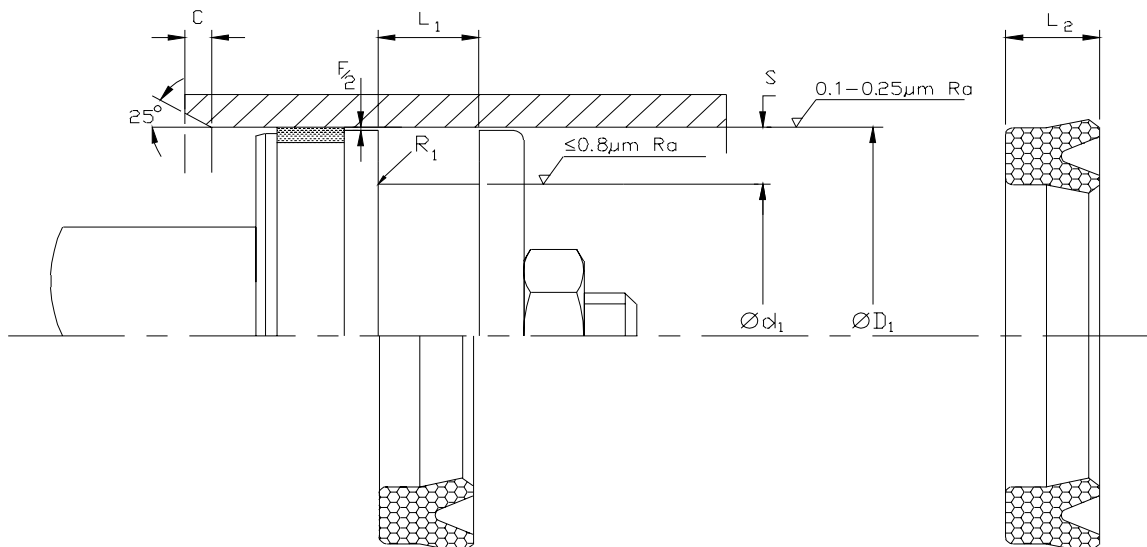

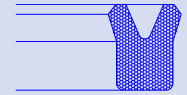
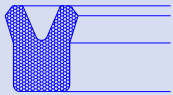

Nominal Dimensions & Machining Tolerances

Claron Part Number	H10	js11	+0.25 -0.00	Nominal	Nominal	Min	Max.
	ØD ₁	Ød ₁	L ₁	L ₂	S	C	R ₁
CPU 062039	16.00	10.00	5.00	4.40	4.00	3.00	0.20
CPU 078047	20.00	12.00	9.00	8.40	4.00	3.00	0.20
CPU 078055	20.00	14.00	4.50	4.00	3.00	3.00	0.20
CPU 086063	22.00	16.00	5.00	4.40	3.00	3.00	0.20
CPU 098055	25.00	14.00	6.10	5.50	5.50	4.00	0.30
CPU 098063	25.00	16.00	8.25	7.50	4.50	4.00	0.30
CPU 098070	25.00	18.00	6.75	6.00	3.50	3.00	0.20
CPU 102063	26.00	16.00	8.75	8.00	5.00	4.00	0.30
CPU 102070	26.00	18.00	5.70	5.00	4.00	3.00	0.20
CPU 110078	28.00	20.00	7.25	6.50	4.00	3.00	0.20
CPU 110078/1	28.00	20.00	5.70	5.00	4.00	3.00	0.30
CPU 110078/2	28.00	20.00	4.50	4.00	4.00	3.00	0.20
CPU 118078	30.00	20.00	8.75	8.00	5.00	4.00	0.30
CPU 118086	30.00	22.00	6.75	6.00	4.00	3.00	0.20
CPU 118088	30.00	22.40	5.70	5.00	3.80	3.00	0.30
CPU 129098	33.00	25.00	6.30	5.70	4.00	3.00	0.20
CPU 129098/1	33.00	25.00	8.75	8.00	4.00	3.00	0.20
CPU 129098/2	33.00	25.00	5.60	5.00	4.00	3.00	0.20
CPU 137098	35.00	25.00	8.75	8.00	5.00	4.00	0.30
CPU 137098/1	35.00	25.00	10.75	10.00	5.00	4.00	0.30
CPU 137098/2	35.00	25.00	7.50	7.30	5.00	4.00	0.30
CPU 139110	35.50	28.00	5.70	5.00	3.75	3.00	0.20
CPU 149098	38.00	25.00	10.75	10.00	6.50	4.00	0.30
CPU 157078	40.00	20.00	12.00	11.00	10.00	5.00	0.40
CPU 157098	40.00	25.00	10.75	10.00	7.50	5.00	0.40
CPU 157118	40.00	30.00	10.75	10.00	5.00	4.00	0.30
CPU 157118/1	40.00	30.00	7.00	6.00	5.00	4.00	0.30
CPU 163124	41.50	31.50	7.00	6.00	5.00	4.00	0.30
CPU 165118	42.00	30.00	10.75	10.00	6.00	4.00	0.30
CPU 165125	42.00	32.00	6.30	5.80	5.00	4.00	0.30
CPU 169110	43.00	28.00	11.00	10.00	7.50	5.00	0.40
CPU 173141	44.00	36.00	8.75	8.00	4.00	3.00	0.20
CPU 177118	45.00	30.00	10.75	10.00	7.50	5.00	0.30
CPU 177137	45.00	35.00	10.75	10.00	5.00	4.00	0.30
CPU 177137/1	45.00	35.00	7.00	6.00	5.00	4.00	0.30
CPU 181141	46.00	36.00	8.00	7.30	5.00	4.00	0.30
CPU 196118	50.00	30.00	10.75	10.00	10.00	4.00	0.30
CPU 196137	50.00	35.00	10.75	10.00	7.50	5.00	0.40
CPU 196157	50.00	40.00	10.75	10.00	5.00	4.00	0.30
CPU 196157/2	50.00	40.00	5.75	5.00	5.00	4.00	0.30
CPU 196157/3	50.00	40.00	7.00	6.00	5.00	4.00	0.30
CPU 196165	50.00	42.00	6.30	5.80	4.00	3.00	0.20
CPU 216149	55.00	38.00	10.75	10.00	8.50	5.00	0.40
CPU 216157	55.00	40.00	10.75	10.00	7.50	5.00	0.40
CPU 216177/1	55.00	45.00	6.75	6.00	5.00	4.00	0.30

Single Acting Piston Seal

CPU

Metric

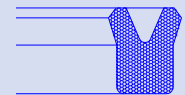
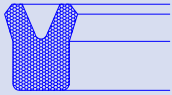

Nominal Dimensions & Machining Tolerances

Claron Part Number	H10	js11	+0.25 -0.00	Nominal	Nominal	Min	Max.
	ØD ₁	Ød ₁	L ₁	L ₂	S	C	R ₁
CPU 216177	55.00	45.00	10.75	10.00	5.00	4.00	0.30
CPU 236157	60.00	40.00	12.75	12.00	10.00	5.00	0.40
CPU 236157/1	60.00	40.00	19.00	18.00	10.00	5.00	0.40
CPU 236177	60.00	45.00	10.75	10.00	7.50	5.00	0.40
CPU236196	60.00	50.00	10.75	10.00	5.00	4.00	0.30
CPU 236196/1	60.00	50.00	7.00	6.00	5.00	4.00	0.30
CPU 248208	63.00	53.00	6.75	6.00	5.00	4.00	0.30
CPU 255177	65.00	45.00	10.75	10.00	10.00	5.00	0.40
CPU 255196	65.00	50.00	10.75	10.00	7.50	5.00	0.40
CPU 255216/2	65.00	55.00	7.00	6.00	5.00	4.00	0.30
CPU 255216	65.00	55.00	12.75	12.00	5.00	4.00	0.30
CPU 275196	70.00	50.00	12.75	12.00	10.00	5.00	0.40
CPU 275196/1	70.00	50.00	10.75	10.00	10.00	5.00	0.40
CPU 275196/2	70.00	50.00	19.00	18.00	10.00	5.00	0.40
CPU 275236/1	70.00	60.00	7.00	6.00	5.00	4.00	0.30
CPU 275236	70.00	60.00	12.75	12.00	5.00	4.00	0.30
CPU 295216	75.00	55.00	13.00	12.00	10.00	5.00	0.60
CPU 295255	75.00	65.00	12.75	12.00	5.00	4.00	0.30
CPU 295255/1	75.00	65.00	10.75	10.00	5.00	4.00	0.30
CPU 295255/2	75.00	65.00	7.50	6.50	5.00	4.00	0.30
CPU 307228	78.00	58.00	16.00	15.00	5.00	4.00	0.30
CPU 314236	80.00	60.00	12.75	12.00	10.00	5.00	0.40
CPU 314236/1	80.00	60.00	19.00	18.00	10.00	5.00	0.40
CPU 314255	80.00	65.00	12.75	12.00	7.50	5.00	0.40
CPU 314275/3	80.00	70.00	7.00	6.00	5.00	4.00	0.30
CPU 314275/1	80.00	70.00	9.00	8.00	5.00	4.00	0.30
CPU 314275/2	80.00	70.00	11.00	10.00	5.00	4.00	0.30
CPU 314275	80.00	70.00	12.75	12.00	5.00	4.00	0.30
CPU 334255	85.00	65.00	13.00	12.00	10.00	5.00	0.60
CPU 334275	85.00	70.00	12.75	12.00	7.50	5.00	0.40
CPU 334295	85.00	75.00	7.00	6.00	5.00	4.00	0.30
CPU 354275	90.00	70.00	12.75	12.00	10.00	5.00	0.40
CPU 354295	90.00	75.00	12.75	12.00	7.50	5.00	0.40
CPU 354314/1	90.00	80.00	7.00	6.00	5.00	4.00	0.30
CPU 354314	90.00	80.00	12.75	12.00	5.00	4.00	0.30
CPU 374295	95.00	75.00	13.00	12.00	10.00	5.00	0.60
CPU 374314	95.00	80.00	10.75	10.00	7.50	5.00	0.40
CPU 393314	100.00	80.00	12.75	12.00	10.00	5.00	0.40
CPU 393334/1	100.00	85.00	10.00	9.00	7.50	5.00	0.40
CPU 393334	100.00	85.00	12.75	12.00	7.50	5.00	0.40
CPU 413334	105.00	85.00	13.00	12.00	10.00	5.00	0.60
CPU 4133354/1	105.00	90.00	10.00	9.00	7.50	5.00	0.40
CPU 413354	105.00	90.00	12.75	12.00	7.50	5.00	0.40
CPU 433354	110.00	90.00	13.00	12.00	10.00	5.00	0.60
CPU 433374/1	110.00	95.00	10.00	9.00	7.50	5.00	0.40

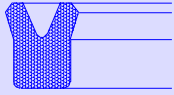

Claron Polyseal®
Single Acting Piston Seal Metric
CPU

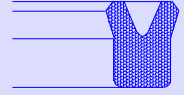

Nominal Dimensions & Machining Tolerances

Claron Part Number	H10	js11	+0.25 -0.00	Nominal	Nominal	Min	Max.
	ØD ₁	Ød ₁	L ₁	L ₂	S	C	R ₁
CPU 433374	110.00	95.00	12.75	12.00	7.50	5.00	0.40
CPU 452374	115.00	95.00	13.00	12.00	10.00	5.00	0.60
CPU 452393/1	115.00	100.00	10.00	9.00	7.50	5.00	0.40
CPU 452393	115.00	100.00	12.75	12.00	7.50	5.00	0.40
CPU 472393	120.00	100.00	13.00	12.00	10.00	5.20	0.60
CPU 492393	125.00	100.00	15.75	15.00	12.50	6.50	0.60
CPU492413	125.00	105.00	17.00	15.00	10.00	5.00	0.60
CPU 492413/1	125.00	105.00	13.00	12.00	10.00	5.00	0.60
CPU 492433	125.00	110.00	12.75	12.00	7.50	5.00	0.40
CPU 492440	125.00	112.00	10.00	9.00	6.50	5.00	0.30
CPU 492452	125.00	115.00	12.75	12.00	5.00	4.00	0.30
CPU 511433	130.00	110.00	17.00	15.00	10.00	5.00	0.60
CPU 551472	140.00	120.00	17.00	15.00	10.00	5.00	0.60
CPU 551492	140.00	125.00	10.00	9.00	7.50	5.00	0.40
CPU 570492	145.00	125.00	17.00	15.00	10.00	5.00	0.60
CPU 590511	150.00	130.00	17.00	15.00	10.00	5.00	0.60
CPU 590535	150.00	136.00	10.00	9.00	7.50	5.00	0.40
CPU 610551	155.00	140.00	10.00	9.00	7.50	5.00	0.40
CPU 629551	160.00	140.00	17.00	15.00	10.00	5.00	0.60
CPU 629570	160.00	145.00	10.00	9.00	7.50	5.00	0.40
CPU 669590	170.00	150.00	17.00	15.00	10.00	5.00	0.60

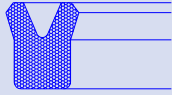

ClaronPolyseal®
Single Acting Piston Seal Imperial
CPU

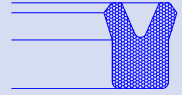

Nominal Dimensions & Machining Tolerances

Claron Part Number	H10	js11	+0.010 -0.000	Nominal	Nominal	Min	Max.
	ØD ₁	Ød ₁	L ₁	L ₂	S	C	R ₁
CPU 056031	0.562	0.312	0.275	0.250	0.125	0.093	0.016
CPU 100062	1.000	0.625	0.300	0.281	0.187	0.093	0.016
CPU 100062/1	1.000	0.625	0.208	0.187	0.187	0.093	0.016
CPU 125087	1.250	0.875	0.208	0.187	0.187	0.093	0.016
CPU 150100	1.500	1.000	0.275	0.250	0.250	0.125	0.032
CPU 162112	1.625	1.125	0.550	0.500	0.250	0.125	0.032
CPU 175112	1.750	1.125	0.550	0.500	0.312	0.156	0.032
CPU 175125	1.750	1.250	0.312	0.280	0.250	0.125	0.032
CPU 175125/1	1.750	1.250	0.395	0.375	0.250	0.125	0.032
CPU 187150	1.875	1.500	0.275	0.250	0.187	0.093	0.016
CPU 200137	2.000	1.375	0.582	0.562	0.312	0.156	0.032
CPU 200137/1	2.000	1.375	0.520	0.500	0.312	0.156	0.032
CPU 225150	2.250	1.500	0.550	0.500	0.375	0.187	0.046
CPU 225162	2.250	1.625	0.457	0.437	0.312	0.156	0.032
CPU 237175	2.375	1.750	0.582	0.562	0.312	0.156	0.032
CPU 237175/1	2.375	1.750	0.395	0.375	0.312	0.156	0.032
CPU 250150	2.500	1.500	0.665	0.625	0.500	0.156	0.032
CPU 250212	2.500	2.125	0.280	0.250	0.187	0.093	0.016
CPU 262200	2.625	2.000	0.582	0.562	0.312	0.156	0.032
CPU 262200/1	2.625	2.000	0.340	0.312	0.312	0.156	0.032
CPU 262212	2.625	2.125	0.395	0.375	0.250	0.125	0.032
CPU 275200	2.750	2.000	0.520	0.500	0.375	0.187	0.046
CPU 287187	2.875	1.875	0.665	0.625	0.500	0.216	0.046
CPU 300225	3.000	2.250	0.520	0.500	0.375	0.187	0.046
CPU 300237	3.000	2.375	0.582	0.562	0.312	0.156	0.032
CPU 312250	3.125	2.500	0.582	0.562	0.312	0.156	0.032
CPU 325262	3.250	2.625	0.582	0.562	0.312	0.156	0.032
CPU 337275	3.375	2.750	0.582	0.562	0.312	0.156	0.032
CPU 350250	3.500	2.500	0.730	0.687	0.500	0.216	0.046
CPU 350275	3.500	2.750	0.520	0.500	0.375	0.187	0.046
CPU 362300	3.625	3.000	0.582	0.562	0.312	0.156	0.032
CPU 362300/1	3.625	3.000	0.340	0.312	0.312	0.156	0.032
CPU 375300	3.750	3.000	0.520	0.500	0.375	0.187	0.046
CPU 387325	3.875	3.250	0.582	0.562	0.312	0.156	0.032
CPU 400300	4.000	3.000	0.730	0.687	0.500	0.216	0.046
CPU 412337	4.125	3.375	0.582	0.562	0.375	0.156	0.032
CPU 425350	4.250	3.500	0.530	0.500	0.375	0.156	0.032
CPU 425362	4.250	3.625	0.582	0.562	0.312	0.156	0.032
CPU 450350	4.500	3.500	0.730	0.687	0.500	0.216	0.046
CPU 487425	4.875	4.250	0.582	0.562	0.312	0.156	0.032
CPU 500437	5.000	4.375	0.582	0.562	0.312	0.156	0.032
CPU 525462	5.250	4.625	0.582	0.562	0.312	0.156	0.032
CPU 600537	6.000	5.375	0.582	0.562	0.312	0.156	0.032
CPU 700637	7.000	6.375	0.582	0.562	0.312	0.156	0.032