

Design

Designed for use on split pistons, the seal is a precision moulded Nitrile rubber element with bonded rubberised fabric reinforcements. The seal is designed with initial radial interference such that when fitted low pressure sealing is effected. Rubberised fabric has the advantage of retaining the sealing media within its surface, thus reducing friction and wear. Style DP has proven to be effective over a wide range of applications.

Operating Conditions

Maximum Pressure	
Max Speed	Temp. Range
m/s	-30°C to 100°C
0.50	250 Bar
0.15	400 Bar

These range parameters are Maximum simultaneous conditions.

Optimum service conditions are affected by temperature, speed, pressure, surface finish and extrusion gaps.

Refer to Appendix 1 for further information.

Maximum Diametral Clearance F

Pressure Bar

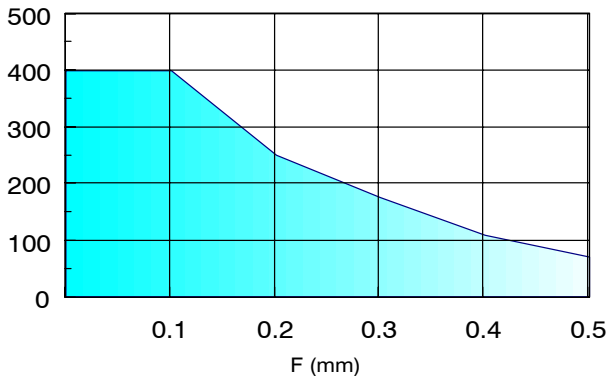

Continuous operating temperature for various fluids

NBR Rubber		
DIN	Hydraulic Fluid Description	°C
H	Mineral oil without additives	100
H-L	Mineral Fluid with anti corrosion and anti ageing additives	100
H-LP	Mineral oil as HL plus additives reducing wear, raising load	100
H-LPD	Mineral oil as H-LP but with detergents and dispersants	100
H-V	Mineral oil as H-LP plus improved viscosity temp.	100
HFA E	Emulsions of mineral oil in water. Water content 80-95%	55
HFA S	Synthetic oil in water. Water content 80-95%	55
HFB	Emulsions of water in mineral oil. Water content 40%	60
HFC	Aqueous polymer solutions. Water content 35%	60
HFD R	Phosphoric acid ester based	NS
HFD S	Chlorinated hydrocarbon based	NS
HFD T	Mixtures of HFD R and HFD S	NS
HEPG	Polyglycol based	NS
HETG	Vegetable Oil based	60
HEES	Fully synthetic ester based	NS

Note: Clearance gap F is the maximum permissible. i.e. gap completely on one side, in the temperature range of -30°C to 100°C. The use of a suitably selected Claron bearing ring will effectively reduce the clearance gap F max. to a value closer to F/2 thus increasing the pressure capability of the seal.

Housing

For surface finish and recommended lead in chamfers refer to the illustration below. For housing dimensions and machining tolerances refer to the catalogue page of selected seal. Refer to Appendix 4 for value of tolerance symbols.

Fitting

For the seal to function correctly, it is important that care be taken in fitting the seal within its housing. For a detailed checklist, refer to Appendix 3.

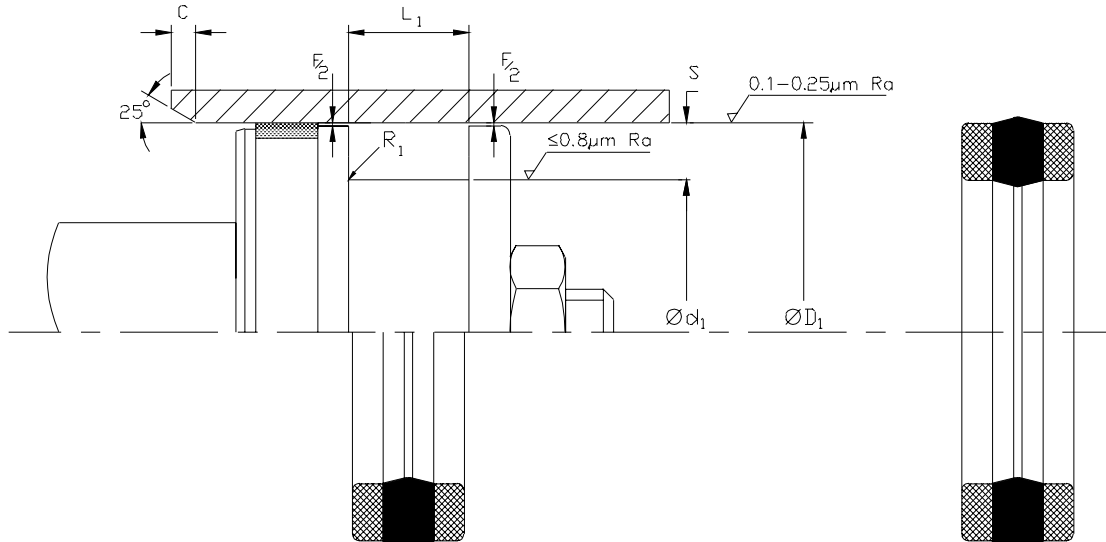

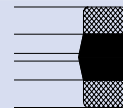
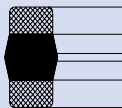

Nominal Dimensions & Machining Tolerances

Claron Part Number	H11 ØD ₁	js11 Ød ₁	+0.25 -0.00 L ₁	Nominal S	Minimum C	Maximum R ₁
DP 098059	25	15	12.5	5.0	2.5	0.4
DP 126086	32	22	12.5	5.0	2.5	0.4
DP 157098/1	40	25	19.0	7.5	4.0	0.6
DP 177102	45	26	25.0	9.5	5.0	0.8
DP 196137/1	50	35	19.0	7.5	4.0	0.6
DP 216157	55	40	19.0	7.5	4.0	0.6
DP 236157/1	60	40	25.0	10.0	5.0	0.8
DP 236177/1	60	45	19.0	7.5	4.0	0.6
DP 248169	63	43	25.0	10.0	5.0	0.8
DP 248188	63	48	19.0	7.5	4.0	0.6
DP 275196/2	70	50	25.0	10.0	5.0	0.8
DP 314236/2	80	60	25.0	10.0	5.0	0.8
DP 354275/1	90	70	25.0	10.0	5.0	0.8
DP393295	100	75	20.0	12.5	6.5	1.2
DP 393314	100	80	25.0	10.0	5.0	0.8
DP 433354	110	90	25.0	10.0	5.0	0.8
DP 472393	120	100	25.0	10.0	5.0	0.8
DP 492393/2	125	100	32.0	12.5	6.5	1.2
DP 551472	140	120	25.0	10.0	5.0	0.8
DP 570492	145	125	25.0	10.0	5.0	0.8
DP 590492/1	150	125	32.0	12.5	6.5	1.2
DP 629531	160	135	32.0	12.5	6.5	1.2
DP 629551	160	140	25.0	10.0	5.0	0.8

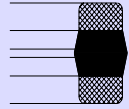
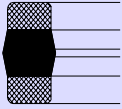

Nominal Dimensions & Machining Tolerances

Claron Part Number	H11 ØD ₁	js11 Ød ₁	+0.025" +0.015" L ₁	Nominal S	Minimum C	Maximum R ₁
DP 075037/1	0.750	0.375	0.468	0.187	0.093	0.008
DP 087050	0.875	0.500	0.312	0.187	0.093	0.008
DP 100062	1.000	0.625	0.468	0.187	0.093	0.008
DP 112062	1.125	0.625	0.500	0.250	0.125	0.015
DP 112062/1	1.125	0.625	0.625	0.250	0.125	0.015
DP 125075	1.250	0.750	0.625	0.250	0.125	0.015
DP 137087	1.375	0.875	0.625	0.250	0.125	0.015
DP 150100	1.500	1.000	0.625	0.250	0.125	0.015
DP 162100	1.625	1.000	0.750	0.312	0.156	0.025
DP 175112	1.750	1.125	0.750	0.312	0.156	0.025
DP 200137	2.000	1.375	0.750	0.312	0.156	0.025
DP 212150	2.125	1.500	0.750	0.312	0.156	0.025
DP 225162	2.250	1.625	0.750	0.312	0.156	0.025
DP 237175	2.375	1.750	0.750	0.312	0.156	0.025
DP 250187	2.500	1.875	0.750	0.312	0.156	0.025
DP 262200	2.625	2.000	0.750	0.312	0.156	0.025
DP 275200	2.750	2.000	0.937	0.375	0.187	0.031
DP 300225	3.000	2.250	0.937	0.375	0.187	0.031
DP 300225/4	3.000	2.250	0.593	0.375	0.187	0.031
DP 325250	3.250	2.500	0.937	0.375	0.187	0.031
DP 325250/3	3.250	2.500	0.562	0.375	0.187	0.031
DP 350275	3.500	2.750	0.937	0.375	0.187	0.031
DP 375300	3.750	3.000	0.937	0.375	0.187	0.031
DP 400325	4.000	3.250	0.937	0.375	0.187	0.031
DP 402324/1	4.024	3.245	0.875	0.389	0.187	0.031
DP 425350	4.250	3.500	0.937	0.375	0.187	0.031
DP 450350	4.500	3.500	1.250	0.500	0.218	0.046
DP475375	4.750	3.750	1.250	0.500	0.218	0.046
DP 500400	5.000	4.000	1.250	0.500	0.218	0.046
DP 525425	5.250	4.250	1.250	0.500	0.218	0.046
DP 550450	5.500	4.500	1.250	0.500	0.218	0.046
DP 600500	6.000	5.000	1.250	0.500	0.218	0.046
DP 700600	7.000	6.000	1.250	0.500	0.218	0.046
DP 800700	8.000	7.000	1.250	0.500	0.218	0.046